V2 Series Small Power Universal AC Drive/VFD

Operation Manual

220V Power: 0.4KW – 5.5KW

380V Power: 0.4KW – 7.5KW

- Please read the instructions carefully and understand the content so as to install and use correctly.
- Please give the instructions to the final user and save it carefully
- The technological standards of this product may be changed, but we will not make a notice about it.

Declaration

Thanks for choosing the VFD. Before you use it, please read the instructions carefully, and making sure that you have known about all the safety precaution.

Safety Precaution:

1. Before wiring, please make sure that the input power is off.
2. The wiring work should be operated by the professional electrical engineer.
3. The grounding terminals must be connected with the ground.
4. Having paused circuit wiring emergently, please make sure that the check is effective.
5. Do not connect the output wire of the VFD with the shell, and pay attention that the output wire should not be short-circuited.
6. Please check whether the voltage of the AC main circuit power is consistent with the rated voltage of the VFD.
7. Do not do the voltage withstand test on the VFD.
8. Please connect the brake resistor according to the wiring diagram.
9. Do not connect the power to the U, V, W output terminals.
10. Do not connect the contactor with the output circuit.
11. Make sure to install a protection cover before power-on. When removing the cover, be sure to make the power off.
12. If you want to reset the VFD with the retry function, do not get close to the mechanical equipment, because the VFD will restart suddenly when the alarm stops.
13. Confirm that the operation signal is cut off. Before reset the alarm device, or the VFD may start suddenly.
14. Do not touch the terminals of VFD, which are very dangerous because there is high voltage on them.
15. When power is on, do not change the wiring and terminal.
16. Cut off the main circuit power before doing some check and maintain work.
17. Do not arbitrarily reform the VFD.

1、 Technical Data

Main Data of V2 series AC Drive/VFD

Model	Power	Voltage	Output (A)	size
				L*W*H (mm)
V2-0R7G-S2	0.75KW	Single Phase AC 220V-240V 50Hz/60Hz	4	150*115*150
V2-1R5G-S2	1.5KW		7	150*115*150
V2-2R2G-S2	2.2KW		9.5	150*115*150
V2-3R0G-S2	3.0KW		11.5	150*115*150
V2-4R0G-S2	4.0KW		15	210*118*180
V2-5R5G-S2	5.5KW		20	210*118*180
V2-0R7G-T4	0.75KW	Three Phase AC 380V-440V 50Hz/60Hz	2.5	150*115*150
V2-1R5G-T4	1.5KW		4.1	150*115*150
V2-2R2G-T4	2.2KW		5.8	150*115*150
V2-3R0G-T4	3.0KW		7.5	150*115*150
V2-4R0G-T4	4.0KW		9.4	210*118*180
V2-5R5G-T4	5.5KW		12.6	210*118*180
V2-7R5G-T4	7.5KW		16.1	210*118*180

Braking resistor Models

Model	Power	Voltage	Braking resistor Power	Braking resistor
V2-0R7G-S2	0.75KW	Single Phase AC 220V-240V 50Hz/60Hz	100 W	200 Ω
V2-1R5G-S2	1.5KW		300 W	100 Ω
V2-2R2G-S2	2.2KW		300 W	100 Ω
V2-3R0G-S2	3.0KW		500 W	100 Ω
V2-4R0G-S2	4.0KW		500 W	75 Ω
V2-5R5G-S2	5.5KW		1000 W	75 Ω
V2-0R7G-T4	0.75KW	Three Phase AC 380V-440V 50Hz/60Hz	100 W	750 Ω
V2-1R5G-T4	1.5KW		300 W	400 Ω
V2-2R2G-T4	2.2KW		300 W	250 Ω
V2-3R0G-T4	3.0KW		300 W	250 Ω
V2-4R0G-T4	4.0KW		500 W	150 Ω
V2-5R5G-T4	5.5KW		800 W	100 Ω
V2-7R5G-T4	7.5KW		1000 W	75 Ω

2、 Installment and Wiring

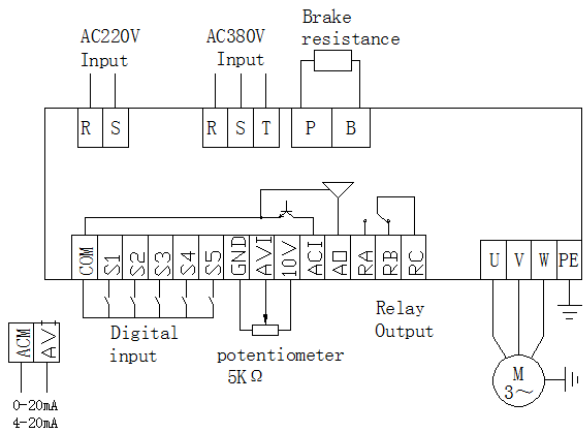

Terminal Function Instru

Terminal	Function	Setting and Instruction
R、S、T	AC Drive/VFD: 380V Model connect with R、S、T terminals 220V Model connect with R、S or R、T terminals (decided by the labels on the terminals)	Air switch should be used as the over-current protection device in front of the VFD power. If there is LCDI, and it is afraid of breakdown, please choose the LCDI whose sensitivity level is above 200mA and reaction period last more than 100ms.
U、V、W	VFD output, connected with electrical machine	In order to reduce the leakage of current, the connection wire should not be over 50 meters.
P、B	Connected with braking resistor	According to the list of braking resistors, choose an appropriate one.
PE	Connected with the ground	The VFD should be connected with the ground well.

Terminal	Function	Setting and Instruction
COM	Signal public terminal	Zero potential of digital signal
S1	Digital input S1	Set according to parameter F2.13, and factory set defaults to be FWD.
S2	Digital input S2	Set according to parameter F2.14, and factory set defaults to be REV
S3	Digital input S3	Set according to parameter F2.15, and factory set defaults to be the first one of multistage speed.
S4	Digital input S4	Set according to parameter F2.16, and factory set defaults to be the second one of multistage speed
S5	Digital input S5	Set according to parameter F2.17, and factory set defaults to be external RST.
GND	Signal public terminal	Zero potential of analog input signal
AVI	0-10V signal input	0-10V, input resistance: >50K Ω
10V	Frequency Setting potentiometer power source	+10V, the maximum is 10mA
ACI	4-20mA analog input	4-10mA, input resistance: 100 Ω
A0	Analog output	Set according to parameter F2.10
RA、RB、RC	Relay output	Set according to parameter F2.20 Contact rating: AC 250V/3A DC 24V/2A

3、 Operation

① Panel and Methods

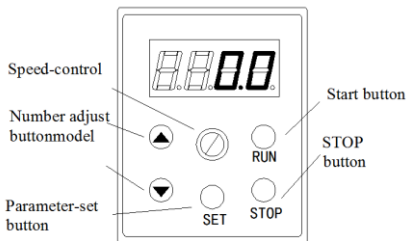

Attention:

If the power is on, it shows 0.0 on the panel. (output frequency)

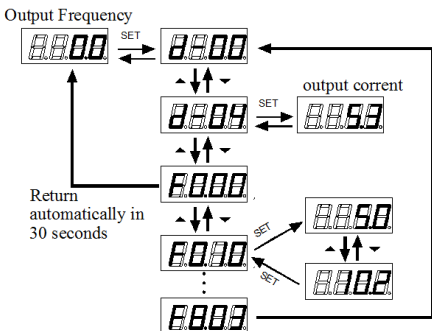

After setting parameter, the way to return the original:

1. When the power is off, make it on again
2. Select the parameter d-00, and click SET.

② VFD Operation Command Mode

VFD operation command mode is set by parameter F0.02: There are two kinds of command mode: panel control start / stop and terminal control start / stop:

(1) **Panel control start/stop:** (The factory set defaults to be controlled by panel.)

When you use the panel to control the VFD, you should remember that clicking the green button means start the VFD and clicking the red button means stop. Before any operation, the VFD defaults to start FWD. FWD and REV are set by input terminal S1-S5. (the REV set is 4)

(2) **Terminal control Start/Stop**

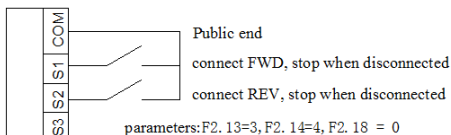

Two-wire Control Model 1

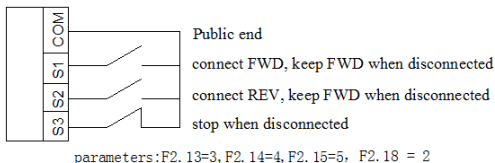

Three-wire Control Model 1

③ VFD Frequency Setting Mode

The VFD frequency setting mode is set by F0.03. When F0.03 = 0, the running frequency is set by potentiometer. When F0.03 = 3, the running frequency is input by AVI (0-10V can be connected with potentiometer); when F0.03 = 5, the running frequency is input by ACI (4-20mA). When F0.03 = 2, it is controlled by the external terminal (the switch value is set to frequency increment / decrement).

4、Parameters list

Parameter	Name	Factory Value	Set Scope	Instruction
F0- The basic running parameter				
F0.00	VFD power	According to VFDmodel	0.1-99.9kw	The current power
F0.01	App version	1.0	1.0-99.9	The current version
F0.02	Running command	0	0-1	0: Panel running command 1: Terminal running command
F0.03	Frequency setting	0	0-5	0: panel potentiometer input 1: number set, adjust by the up/down button on the panel 2: number set, adjust by the terminal up/down 3: AVI analog quantity set (0-10V) 4: combination set (F1.15) 5: ACI set (4-20mA)
F0.04	Maximum input frequency	50.0Hz	50.0-999Hz	The maximum is the highest frequency value that it is allowed to output, which is also the based standard of the acceleration and deceleration.
F0.05	The upper limit of frequency	50.0Hz	50.0-999Hz	The running frequency cannot be over the upper limit.
F0.06	The lower limit of frequency	0.0Hz	0-the upper limit	The running frequency cannot be less than the lower limit.
F0.07	Solutions when reaching the lower limit	0	0-2	0: running at 0 1: running at lower limit 2: stop
F0.08	Running frequency setting	0	0-the upper limit	the value is original one
F0.09	Digital frequency control	0000	0000-2111	A place: power-down storage 0: save, 1: do not save Ten: keep stop 0: hold, 1: do not hold Hundreds: UF / DOWN negative frequency adjustment

Parameter	Name	Factory Value	Set Scope	Instruction
				0: invalid, 1: valid Thousands digit: PID, PLC frequency superposition 0: invalid, 1: F0.03 + PID, 2: F0.03 + PLC
F0.10	Acceleration time	According to VFD model	0-255s	The time it takes for the VFD to accelerate from zero to the maximum output frequency
F0.11	Deceleration time	According to VFD model	0-255s	The time it takes for the VFD to decelerate from the maximum output frequency to zero
F0.12	Running direction setting	0	0-2	0: FWD 1: REV 2: banned REV
F0.13	V/F Curve setting	0	0-2	0: Wirear curve 1: Square curve 2: Multi-point VF curve
F0.14	Torque Lifting Value	According to the VFD model	0.0~30.0%	Manual torque listing value, if large torque is required, set to 0.0; this value set is the percentage of rated voltage.
F0.15	Torque Lifting Value Cutoff Frequency	15.0Hz	0.0~50.0Hz	This setting is the lifting cutoff frequency point for manual torque listing value.
F0.16	Carrier Frequency Setting	According to the VFD model	2.0~8.0KHz	For the silent operation, you can increase the carrier frequency to meet the requirements, but increasing the carrier frequency will increase the heat output of the VFD.
F0.17	V/F Frequency Value F1	12.5Hz	0.1-frequency value F2	
F0.18	V/F Voltage Value V1	25.0%	0.1-voltage value F2	
F0.19	V/F Frequency Value F2	25.0Hz	Frequency value F1-F3	
F0.20	V/F Voltage Value V2	50.0%	Voltage value V1-V3	

Parameter	Name	Factory Value	Set Scope	Instruction
F0.21	V/F Frequency Value F3	37.5Hz	Frequency value F2-rated frequency(F4.03)	<p>V</p> <p>Rating voltage</p> <p>V3</p> <p>V2</p> <p>V1</p> <p>F1</p> <p>F2</p> <p>F3 Maximum output frequency</p> <p>Hz</p>
F0.22	V/F Voltage Value V3	75%	Voltage value V2-100.0% (rated voltage) [F4.00]	
F0.23	User's code	0	0-9999	
F1- Assisted running parameters				
F1.00	DC braking mode when starting	00	0000-0001	Unit: Start mode 0: Start from starting frequency 1: First start DC braking and then the starting frequency Tens: Power-off or abnormal restarting mode 0: invalid 1: Started from the starting frequency Hundreds: Reserved Thousands: Reserved
F1.01	DC braking start frequency	1.0Hz	0.0-50.0Hz	After the frequency reaches the defaulting value, start DC braking
F1.02	DC brake voltage when starting	0.0%	0.0-50.0% rating voltage	Apply DC braking voltage value
F1.03	DC braking time	0.0s	0.0-30.0s	The time for applying DC braking
F1.04	Shutdown mode	0	0-1	0: deceleration and stop 1: freely stop
F1.05	DC brake	0.0Hz	0.0-the	After the frequency reaches the

Parameter	Name	Factory Value	Set Scope	Instruction
	starting frequency when stop		upper limit	defaulting value, start DC braking
F1.06	DC brake voltage when stop	0.0%	0.0-50.0% rating voltage	Apply DC braking voltage value
F1.07	DC braking time when stop	0.0s	0.0-30.0s	The time for applying DC braking
F1.08	DC brake waiting time when stop	0.00s	0.00-99.99s	After reaching the braking frequency, delay a little while and then start DC braking
F1.09	FWD jog frequency setting	10.0Hz	0.0-50.0Hz	Set the jog frequency of FWD and REV
F1.10	REV jog frequency setting			
F1.11	Jog acceleration time	According to the VFD model	0.1-255.0s	Set the acceleration and deceleration time
F1.12	Jog deceleration time			
F1.13	Jumping frequency	0.0Hz	0.0-upper limit	Through setting the jumping frequency and scope, make the VFD keep away from the mechanical resonance point of the load
F1.14	Jumping scope	0.0Hz	0.0-10.0Hz	
F1.15	setting model of frequency combination	0	0-7	0: potentiometer +digital frequency 1 1: potentiometer +digital frequency 2 2: potentiometer +AVI 3: Digital frequency 1+AVI 4: Digital frequency 2+AVI 5: Digital frequency 1+ multistage speed 6: Digital frequency 1+ multistage speed 7: potentiometer + multistage speed

Parameter	Name	Factory Value	Set Scope	Instruction
F1.16	Programmable operation control (simple PLC operation)	0000	0000-1221	Unit: PLC control 0: invalid, 1: valid Tens: select the running mode 0: single cycle, 1: continuous cycle, 2: keep the final value after single cycle Hundreds: start mode 0: restart from the first stage 1: start when VFD stops 2: Start when VFD stop and frequency has been initiated. Thousands: Power-off storage selection 0: No storage, 1: Storage
F1.17	Multi-speed frequency 1	5.0Hz	The lower limit- the upper limit	set the frequency of stage 1
F1.18	Multi-speed frequency 2	10.0Hz	The lower limit- the upper limit	set the frequency of stage 2
F1.19	Multi-speed frequency 3	15.0Hz	The lower limit- the upper limit	set the frequency of stage 3
F1.20	Multi-speed frequency 4	20.0Hz	The lower limit- the upper limit	set the frequency of stage 4
F1.21	Multi-speed frequency 5	25.0Hz	The lower limit- the upper limit	set the frequency of stage 5
F1.22	Multi-speed frequency 6	37.5Hz	The lower limit- the upper limit	set the frequency of stage 6
F1.23	Multi-speed frequency 7	50.0Hz	The lower limit- the upper limit	set the frequency of stage 7
F1.24	Running time in stage 1	10.0s	0.0-999.9s	set the running time of stage 1 (unit is chosen by [F1.35], defaulting to be second.)
F1.25	Running time in stage 2	10.0s	0.0-999.9s	set the running time of stage 2 (unit is chosen by [F1.35],

Parameter	Name	Factory Value	Set Scope	Instruction
				defaulting to be second.)
F1.26	Running time in stage 3	10.0s	0.0-999.9s	set the running time of stage 3 (unit is chosen by [F1.35], defaulting to be second.)
F1.27	Running time in stage 4	10.0s	0.0-999.9s	set the running time of stage 4 (unit is chosen by [F1.35], defaulting to be second.)
F1.28	Running time in stage 5	10.0s	0.0-999.9s	set the running time of stage 5 (unit is chosen by [F1.35], defaulting to be second.)
F1.29	Running time in stage 6	10.0s	0.0-999.9s	set the running time of stage 6 (unit is chosen by [F1.35], defaulting to be second.)
F1.30	Running time in stage 7	10.0s	0.0-999.9s	set the running time of stage 7 (unit is chosen by [F1.35], defaulting to be second.)
F1.31	Acceleration and deceleration time in stages: Choice 1	0000	0000-1111	Unit: acceleration and deceleration time in stage 1, 0~1 Tens: acceleration and deceleration time in stage 2, 0~1 Hundreds: acceleration and deceleration time in stage 3, 0~1 Thousands: acceleration and deceleration time in stage 4, 0~1
F1.32	Acceleration and deceleration time in stages: Choice 2	000	000-111	Unit: acceleration and deceleration time in stage 5, 0~1 Tens: acceleration and deceleration time in stage 6, 0~1 Hundreds: acceleration and deceleration time in stage 7, 0~1 Thousands: Reserved
F1.33	Acceleration time 2	10.0s	0.1~255.0s	set the acceleration and deceleration time 2
F1.34	Deceleration time 2			
F1.35	Time unit selection	000	000~211	Units: PID Procedural time unit Tens: PLC Simple time unit Hundreds: General acceleration and deceleration time unit Thousands: Reserved

Parameter	Name	Factory Value	Set Scope	Instruction
				0: Each unit is 1 second 1: Each unit is 1 point 1: Each unit is 0.1 seconds
F2- Analog and digital input and output parameter				
F2.00	AVI input voltage with the lower limit	0.00W	0.00~ 【F2.01】	set the maximum and minimum AVI voltage
F2.01	AVI input voltage with the upper limit	10.0V	【F2.01】~ 10.00V	
F2.02	Relevant set on the lower limit of AVI	0.0%	-100.0%~10 0.0%	set the relevant set according to the maximum and minimum frequency, and the relevant set is the percentage of the maximum frequency [F0.05]
F2.03	relevant set on the upper limit of AVI	100.0%		
F2.04	AVI input voltage with the lower limit	0.00Ma	0.00~ 【F2.05】	set the maximum and minimum ACI input current
F2.05	AVI input voltage with the upper limit	20.00Ma	F2.04】~ 20.00mA	
F2.06	Relevant set on the lower limit of AVI	0.0%	-100.0%~10 0.0%	set the relevant set according to the maximum and minimum frequency, and the relevant set is the percentage of the maximum frequency [F0.05]
F2.07	Relevant set on the upper limit of AVI	100.0%		
F2.08	Analog input signal filtering time constant	0.1s	0.1~5.0s	This parameter is used to filter the AVI, ACI and panel potentiometer input signals, for eliminating the influence of interference.
F2.09	Analog input the limitation of shake reduction deviation	0.00V	0.00~0.10V	When the analog input signal fluctuates frequently around the reference value, you can suppress the frequency fluctuation caused by this fluctuation by setting F2.09.
F2.10	Functional selection of A0	0	0~5	0: Output frequency, 1: Output current,

Parameter	Name	Factory Value	Set Scope	Instruction
	analog output terminals			2: Motor speed, 3: Output voltage, 4: AVI, 5: ACI
F2.11	The lower limit of A0 output	0.00V	0.00~10.00 V	set the maximum and minimum value of AO output
F2.12	The upper limit of A0 output	10.00V		
F2.13	The function of input terminal S1	3	0~27	0: Set aside the control terminal 1: Forward jog control 2: Reverse jog control 3: Forward control (FWD) 4: Reverse control (REV) 5: Three-wire operation control 6: Free-stop control 7: External stop signal input (STOP) 8: External reset signal input (RST) 9: External fault input 10: Increment frequency command (UP) 11: Decrement frequency command (DOWN) 13: Multi-speed selection S1 14: Multi-speed selection S2 15: Multi-speed selection S3 16: Running command channel compulsive terminal 17: reserved 18: DC braking command when stop 19: Frequency switch to AVI 20: Frequency switch to digital frequency 1 21: Frequency switch to digital frequency 2 22: Reserved 23: Counter clear signal 24: Counter triggering signal 25: Timer clear signal 26: Timer triggering signal 27: Acceleration and deceleration
F2.14	The function of input terminal S2	4	0~27	
F2.15	The function of input terminal S3	13	0~27	
F2.16	The function of input terminal S4	14	0~27	
F2.17	The function of input terminal S5	8	0~27	

Parameter	Name	Factory Value	Set Scope	Instruction
				time selection
F2.18	FWD/REV terminals control model	0	0-3	0: three-wire control model 1 1: three-wire control model 1 2: three-wire control model 1 3: three-wire control model 1
F2.19	Terminal function test when the power is on	0	0-1	0: invalid running command when the power is on 1: valid running command when the power is on
F2.20	Functional set of potentiometer R		0~14	0: Idle 1: VFD is ready for operation 2: VFD is running 3: VFD runs at zero speed 4: External fault 5: VFD fault 6: Frequency / speed arrival signal (FAR) 7: Frequency / speed level detection signal (FDT) 8: The output frequency reaches the upper limit 9: The output frequency reaches the lower limit 10: VFD overload warning 11: Timer overflow signal 12: Counter detection signal 13: Counter reset signal 14: Assisted motor
F2.21	Reservation			
F2.22	Time-delay when the switch(R) is turned off	0.0s	0.0~255.0s	the time-relay happens when the potentiometer R turn to the change of output
F2.23	Time-delay when the switch is turned on			
F2.24	The scope of examination when the frequency reaches FAR	5.0Hz	0.0Hz~15.0 Hz	The output frequency is within the positive and negative detection width of the set frequency, and the terminal outputs valid signal (low level).

Parameter	Name	Factory Value	Set Scope	Instruction
F2.25	FDT-level set value	10.0Hz	0.0Hz~the maximum frequency	
F2.26	FDT hysteresis value	1.0Hz	0.0~30.0Hz	
F2.27	UF/DOWN terminal modification speed	1.0Hz/s	0.1Hz~99.9 Hz/s	set the speed of modified frequency when the UP/DOWN terminal set the frequency, et the quantity of frequency's change when the UP/DOWN terminal has short circuit with COM terminal for one second.
F2.28	Pulse input triggering mode setting	0	0~1	0: means the electrical triggering mode 1: means the pulse triggering mode
F2.29	Input terminal effective logical setting	0	0~1	0: means positive logic, et. it is valid when Si terminal is connected with the public terminal but invalid when they are disconnected. 1: means inverse logic, et.It is valid that Si terminal is connected with the public terminal but invalid when they are disconnected.
F2.30	S1 Filter coefficient	5	0~9999	used to set the sensitivity of input terminals,
F2.31	S2 Filter coefficient	5	0~9999	If the digital input terminal is easily disturbed and cause malfunction, increase this parameter to increase the anti-interference ability. However, if the range of setting is too large, the sensitivity of the input terminal will decrease. 1: Represents 2MS scan time unit
F2.32	S3 Filter coefficient	5	0~9999	
F2.33	S4 Filter coefficient	5	0~9999	
F2.34	S5 Filter coefficient	5	0~9999	
F3- PID parameter setting				
F3.00	PID functional setting	1010	0000~2122	Unit: PID adjustment characteristic 0: invalid, 1: negative feedback, 2: positive feedback Tens digit: PID given quantity

Parameter	Name	Factory Value	Set Scope	Instruction
				<p>input channel 0: keyboard potentiometer, 1: number given PID quantity is given by the number, and set by the function code F3.01. 2: Pressure given (MPa, Kg) By setting F3.01, F3.18 given pressure. Hundreds digit: FID feedback input channel 0: AVI, 1: ACI Thousands digit: PID sleep selection 0: invalid, 1: normal hibernation, this method needs to set specific parameters such as F3.10 ~ F3.13. 2: disturbance sleep Same as the parameter setting when the sleep mode is selected as 0, if the PID feedback value is within the range of the F3.14 setting value, the sleep delay time will be maintained and the disturbance sleep will be entered. When the feedback value is less than the wake-up threshold (PID polarity is positive), immediately wake up.</p>
F3.01	The given value is set	0.0%	0.0~100.0%	Use the keyboard to set the given amount of PID control. This function is valid only when the PID given channel selection digit is given (F3.00 ten's digit is 1).
F3.02	Feedback channel benefit- gain	1.00	0.01~10.00	When the feedback channel is not consistent with the setting channel, this function can be used to adjust the signal of feedback channel.
F3.03	Proportional gain P	1.00	0.1~5.00	The adjustment speed of PID is set by two parameters, proportional gain P and Integration Time Ti. If you want a higher speed, you should increase the proportional gain P and decrease the integration
F3.04	Integration time Ti	1.00	0.1~50.0s	
F3.05	Derivative time	2.0s	0.1~10.0s	

Parameter	Name	Factory Value	Set Scope	Instruction
	Td			time; if you want a lower speed, you should decrease the proportional gain P and increase the integration time. Under general conditions, we do not set the derivative time.
F3.06	Sampling period T	0.0s	0.1~10.0s	The larger the sampling period means the slower response but better suppression effect on the interference signal. Generally, it is not set.
F3.07	Deviation limit	0.0s	0.0~20.0%	Deviation limit is the ratio of the given amount and the absolute value which is the deviation between the system feedback amount and the given amount. When the feedback amount is within the deviation limit range, we will not adjust the PID .
F3.08	Closed loop preset frequency	0.0Hz	0.0~the Maximum	The frequency and running time of the VFD before the PID begins to be operated.
F3.09	Holding time of Preset frequency	0.0s	0.0~999.9s	
F3.10	Awaking threshold factor	100.0%	0.0~150.0%	If the actual feedback value is greater than the set value and the VFD output frequency reaches the lower limit frequency, the VFD will turn to sleeping state after the delay time defined by F3.12 (ie zero speed operation; the value is the percentage of the PID set value.)
F3.11	Sober threshold factor	90.0%	0.0~150.0%	If the feedback value is less than the set value, the VFD will turn to sleeping state after waiting for the delay time defined by F3.13; this value is a percentage of the PID set value.
F3.12	Delayed sleep	100.0%	0.0~999.9s	set the time-delay of sleeping

Parameter	Name	Factory Value	Set Scope	Instruction
F3.13	Delayed awaking	1.0s	0.0~999.9s	set time-delay of awaking
F3.14	Feedback and set pressure deviations when entering sleep	0.5%	0.0~10.0%	The parameters of the function is only effective to the disturbance sleeping mode.
F3.15	Burst examination delay time	30.0	0.0~999.9s	set the burst examination delay time
F3.16	High pressure detection threshold	150.0%	0.0~200.0%	When the feedback pressure is greater than or equal to the set value, the squib failure "EPA0" will be reported after the F3.15 squib delay, when the feedback pressure is less than the set value, the squib fault "EPA0" will reset automatically; the threshold is the percentage of the set pressure.
F3.17	Low pressure detection threshold	50.0%	0.0~200.0%	When the feedback pressure is less than the set value, the squib failure "EPA0" will be reported after the F3.15 squib delay, when the feedback pressure is greater than or equal to the set value, the squib fault "EPA0" will reset automatically; the threshold is the percentage of the set pressure.
F3.18	Sensor range	10.0mp	0.00~99.99 (Mpa、Kg)	set the maximum range of sensor
F4- Advanced function parameters				
F4.00	Rated voltage	By model	0~500V	Motor parameter setting
F4.01	Rated current	By model	0.1~999.9A	
F4.02	Rated speed	By model	0~60000Krpm	
F4.03	Rated frequency	50.0Hz	1.0~999.9Hz	
F4.04	Stator resistance	By model	0.001~20.000Ω	Set the motor stator resistance

Parameter	Name	Factory Value	Set Scope	Instruction
F4.05	No-load current	By model	0.1~ 【F4.01】	Set the motor no-load current
F4.06	AVR function	0	0~2	0: invalid, 1: always valid 2: Invalid only when decelerating
F4.07	Keep	0	-	Keep
F4.08	The frequency of automatic fault reset	0	0~10	When the reset number is set to 0, there is not automatic reset function and it can only be manually reset. 10 means that the number of unlimited, that is means numerous times.
F4.09	Fault automatically reset interval time	3.0s	0.5~25.0s	Set fault automatic reset interval time

F5- Protection function parameters

F5.00	Protection settings	0001	0000~1211	Unit: Motor overload protection options 0: invalid, 1:valid tens: PID feedback break protection 0: invalid, 1: Protection action and free downtime hundreds: Keep thousands: Shock suppression options 0: invalid, 1: valid
F5.01	Motor overload protection factor	100%	30%~ 110%	Motor overload protection factor is the percentage of motor rated current value and VFD rated output current value.
F5.02	Under-voltage protection level	180/360V	150-280 300~480V	This function code stipulates the lower limit voltage of DC bus when the VFD works normally.
F5.03	Deceleration voltage limiting factor	1	0: shut down, 1~ 255	This parameter is used to adjust the ability of the VFD to suppress over-voltage during deceleration.
F5.04	Over-voltage limit level	375/790V	350-380 660~760V	The over-voltage limit level defines the operating voltage at

Parameter	Name	Factory Value	Set Scope	Instruction
				over-voltage stall protection
F5.05	Accelerated current limiting factor	125	0: shut down, 1~255	This parameter is used to adjust the VFD's ability to suppress overcurrent during acceleration.
F5.06	Constant current limiting factor	0	0: shut down, 1~255	This parameter is used to adjust the VFD's ability to suppress overcurrent during constant speed.
F5.07	Current limit level	200%	100%~250%	The current limit level defines the current limit for automatic current limit operation and respectively its set value is the percentage of the rated current value
F5.08	Feedback disconnection detection value	0.0%	0.0~100.0%	This value is a percentage of PID given amount. When the PID feedback value continues to be less than the feedback disconnection detection value, the VFD will make the corresponding protection action according to the setting of F5.00. When F5.08=0.0%, This value is invalid.
F5.09	Feedback disconnection detection time	10.0s	0.1~999.9s	when the feedback disconnection occurs, the time-delay before the protective action
F5.10	VFD overload pre-alarm level	120%	120~150%	This is the current threshold of the VFD overload pre-alarm action. its set value is the percentage of VFD rated current
F5.11	AC Drive/VFD overload pre-alarm delay	5.0s	0.0~15.0s	When VFD output current is continuously greater than overload pre-alarm level (F5.10), the time-delay before output overload pre-alarm signal
F5.12	jog priority enable	0	0~1	0: invalid 1: when the VFD is operating, jog priority is highest
F5.13	Oscillation suppression factor	30	0~200	When the motor shock, it is need to set the thousands of F5.00 as valid and open the shock suppression function. And then,
F5.14	Amplitude	5	0~12	

Parameter	Name	Factory Value	Set Scope	Instruction
	suppression factor			adjusting it by setting the shock suppression factor.
F5.15	Oscillation lower limit frequency	5.0Hz	0.0~ 【F5.16】	Generally, if the shock amplitude is great, it is need to increase the F5.13 shock suppression factor, when F5.14~F5.16 do not set. If there are special circumstances, F5.13 ~ F5.16 shell be used in conjunction with each other.
F5.16	Oscillation suppression upper limit frequency	45.0Hz	【F5.15】~ 【F0.05】	
F5.17	By wave limit selection	011	000~111	units: accelerating selection 0: invalid, 1: valid tens: decelerating selection 0: invalid, 1: valid hundreds: constant selection 0: invalid, 1: valid thousands: Keep

F6- Communication parameters (keep)

F7- Supplementary function parameters

F7.00	Counting and timing modes	103	000~303	units: Count arrival process, 0: Single-cycle count, stop output, 1: Single-cycle count, continue to output, 2: Cycle count, stop output 3: Cycle count, continue to output. tens: Keep hundreds: Timing to deal with, 0: Timing to deal with, 1: Single-cycle count, continue to output, 2: Cycle timing, stop output 3: Cycle timing, continue to output. thousands: Keep
F7.01	Counter reset value setting	1	【F7.02】~ 9999	Set the counter reset value
F7.02	Counter detection value setting	1	0~【F7.01】	Set the counter detection value
F7.03	Timing setting	0s	0~9999s	Set the timing time

F8- Manage and display parameters

Parameter	Name	Factory Value	Set Scope	Instruction
F8.00	Run monitoring parameters	0	0~26	The main monitoring interface, the default display items. its corresponding figures is the parameters in group D.
F8.01	Shutdown monitoring parameters	1	0~26	The main monitoring interface, the default display items. its corresponding figures is the parameters in group D.
F8.02	Motor speed display factor	1.00	0.01~99.99	It used to calibrate the speed scale display error and has no effect on the actual speed.
F8.03	Parameter initialization	0	0~2	0: No operation 1: Restore factory settings User parameters by model to restore the factory settings。 2: Clear the fault record
F9- Manufacturer parameters				
F9.00	Manufacturer password		1-9999	A special password set by system
F9.01	Model selection	1	0-14	220V: 0: 0.4KW 1: 0.75KW 2: 1.5KW 3: 2.2KW 4: 4.0KW 5: 5.5KW 6: 7.5KW 380V: 7: 0.4KW 8: 0.75KW 9: 1.5KW 10: 2.2KW 11: 3.0KW 12: 4.0KW 13: 5.5KW 14: 7.5KW
F9.02	Dead time	By model	2.5~4.0μS	2.5~4.0μS 0.4~4.0KW 2.8us 5.5KW~22KW 3.2us
F9.03	Software over-voltage detection value	400/810V	0-450V/900V	Over-voltage detection threshold
F9.04	Voltage correction factor	1.00	0.80~1.20	Bus voltage value used to calibrate the test
F9.05	Current correction factor	1.00	0.80~1.20	The current value used to calibrate the test
F9.06 ~	Keep	0		Keep

Parameter	Name	Factory Value	Set Scope	Instruction
F9.09				
F9.10	Special function selection	By model	0-2	units: Cumulative run time clear selection 0: invalid, 1: valid tens: By model 0: Universal models (G), 1: Light-load models (F), 2: Overloaded model (Z) hundreds: Keep, thousands: Keep.

d- Monitoring parameters group

Parameter	name	scope	Minimum unit
d-00	Output frequency (Hz)	0.0~999.9Hz	0.1Hz
d-01	Set the frequency (Hz)	0.0~999.9Hz	0.1Hz
d-02	Output voltage (V)	0~999V	1V
d-03	Bus voltage (V)	0~999V	1V
d-04	Output current (A)	0.0~999.9A	0.1A
d-05	Motor speed (Krpm)	0~60000Krpm	1Krpm
d-06	Analog input AVI (V)	0.00~10.00V	0.01V
d-07	Analog input ACI(mA)	0.00~20.00mA	0.01mA
d-08	Analog input AO(V)	0.00~10.00V	0.01V
d-09	Keep	-	-
d-10	Keep	-	-
d-11	PID pressure feedback value	0.00~10.00V/ 0.00~99.99(MPa、Kg)	0.01V/(MPa、Kg)
d-12	Current count value	0~9999	1s

d-13	The current timing value (s)	0~9999s	1s
d-14	Input terminal status (S1-S5)	0~1FH	1H
d-15	Output relay status (R)	0~1H	1H
d-16	Keep	Keep	-
d-17	Software upgrade date (year)	2010~2026	1
d-18	Software upgrade date (day, month)	0~1231	1
d-19	The second fault code	0~19	1
d-20	The most recent fault code	0~19	1
d-21	Output frequency at the latest fault (Hz)	0.0~999.9Hz	0.1Hz
d-22	Output current at the latest fault (A)	0.0~999.9A	0.1A
d-23	Bus voltage during the last failure (V)	0~999V	1V
d-24	Keep	Keep	-
d-25	Total running time of VFD (h)	0~9999h	1h

E- Error code			
Error code	Name	Possible cause of the problem	Troubleshooting
E0C1	Accelerate overcurrent during operation	Acceleration time is too short	Increase acceleration time
		VFD power is too small	Use a large power VFD
		V / F curve or torque boost setting is not appropriate	Adjust the V / F curve or torque boost
E0C2	Overcurrent during deceleration	Deceleration time is too short	Extend the deceleration time
		VFD power is too small	Use a large power VFD
E0C3	Overcurrent in	Grid voltage is low	Check the input power

	constant operation	Load is abrupt or abnormal	Check the load or reduce the Load mutation
		VFD power is too small	Use a large power inverter
EHU1	over-voltage during accelerating operation	Input voltage is abnormal	Check the input power
		Restart the rotating motor	Set to start after DC braking
EHU2	Over-voltage during deceleration	Deceleration time is too short	Extend the deceleration time
		Input voltage is abnormal	Check the input power
EHU3	Over-voltage during constant speed operation	Input voltage is abnormal	Check the input power
EHU4	Over-voltage during shut down	Input voltage is abnormal	Check the power supply voltage
ELU0	Under-voltage in operation	Input voltage is abnormal or the relay is not engaged	Check the power supply voltage or seek service from manufacturers
ESC1	Power module fault	VFD output short circuit or touch ground	Check the motor wiring
		VFD transient overcurrent	Reference overcurrent measures
		Abnormal control board or serious interference	Seek service from manufacturers
		Power device is damaged	Seek service from manufacturers
EOL1	VFD overload	V / F curve or torque boost setting is not appropriate	Adjust the V / F curve and torque boost
		Grid voltage is too low	Check the grid voltage
		Acceleration time is too short	Increase acceleration time
		Motor overload	Select a larger power VFD
EOL2	Motor overload	V / F curve or torque boost setting is not appropriate	Adjust the V / F curve and torque boost
		Grid voltage is too low	Check the grid voltage
		Motor blocked or load	Check the load

		mutation is too large	
		Motor overload protection factor is not set correctly	Set the motor overload protection factor correctly
E-EF	External device failure	External device fault input terminal is closed	Disconnect the external device fault input terminal and clear the fault (pay attention to check the cause)
EPID	PID feedback is disconnected	PID feedback line is loose	Check the feedback connection
		The feedback value is less than the breakage detection value	Adjust the detection input threshold
ECCF	Current detection failure	Current sampling circuit fault	Seek service from manufacturers
		Auxiliary power failure	
EEEP	EEPROM read and write errors	EEPROM failure	Seek service from manufacturers
EPAO	Burst tube failure	The feedback pressure is less than the low-pressure detection threshold or greater than or equal to the high-pressure detection threshold	Check the feedback connection or adjust the detection of high and low-pressure threshold
EPOF	Dual CPU communication failure	CPU communication problem	Seek service from manufacturers

5、 Application Cases

(1) VFD's Control of Constant Pressure and Water Supply

A: Control by Electric Contact Pressure Gauge (the easiest way to control)

Make use of electric pressure gauge pressure to control the pressure of water. Only need to connect two wires, one from the green needles, one from the black needles, were connected to the top two of the three terminals on the electrical contact pressure gauge (some gauges may be different). When the water pressure is low, the black needle will be placed under the green needle, and the VFD is in the accelerated start condition. When the water pressure is high, the black needle will be placed on the green needle, and the VFD is in deceleration stop condition. It is very easy to maintain.

For this VFD, the steps are as follows:

- ① Pick up the two wires which are from electric contact pressure gauge, one of which should be connected to the S1, and the other one should be connected to the COM terminal (no need to distinguish between positive and negative terminal).
- ② Set parameter F0.02 = 1 and select external terminal start control.
- ③ Turn the speed control knob on the panel up to the maximum.
- ④ VFD parameter setting: F2.13 = 3 (default), F0.10 = 80, F0.11 = 80, F2.19 = 1

The VFD will start automatically start when the power is on. If it does not start, you can use the wire directly connecting S1 and COM. If the VFD cannot start, it indicates that there are something wrong with the internal settings of the VFD. If it can be activated, it indicates that there are something wrong with the external electrical contact gauge or wires. It can be checked whether the two wires on the electric contact are connected. It should be turned on when the black pin is placed lower than the green pin, it should be turned off when the black pin is placed above the green pin.

B: Controlled by PID constant pressure water supply control (AVI given)

Use the PID control function which is set inside to adjust and control PID, and the collection of water pressure use pressure sensors or remote pressure gauge. Steps:

- ① Let the water pressure signal on the remote pressure gauge connect to GND, AVI, 10V. If it is 2-wire pressure sensor, connected to GND, AVI. The voltage feedback value can be seen on parameter d-06.
- ② If using panel start mode, set parameter F0.02 = 0. If using external terminals to start, set the parameters F0.02 = 1, F2.13 = 3 (default), F2.19 = 1, start signal line connected to S1 and COM.
- ③ parameter settings: F0.10 = 30, F0.11 = 30 acceleration and deceleration time,

can be adjusted according to the actual application

F3.00 = 1011, PID negative feedback, feedback signal is given by AVI, and the given PID is decided by F3.01.

F3.01, used to set the water pressure, and the range is 0-100. Through this parameter, adjust the level of water pressure, which can be adjusted to 20, and then re-adjusted according to the actual situation.

④the speed of PID control:

F3.03 = 1.00 (default), P value parameter adjustment, P value is higher, adjustment speed is faster

F3.04 = 2.0 (default), I value parameter adjustment, the I value is the higher, the adjustment speed is slower

(2) Two speed given mode control

Equipment requirements: Under FWD mode, use the potentiometer knob to adjust the speed; under REV mode, use the multi-stage operation with low speed.

① Parameter setting: F0.02 = 1, F0.03 = 3, F1.17 = 10 (REV running speed 10HZ)

② Wiring: Three wires of potentiometer should be connected to GND, AVI and +10V. FWD signals are connected to S1 and COM and REV signals are connected to S2 and COM, short-circuited between S2 and S3 (set the frequency when REV and select the setting value of multi-speed 1).

(3) Jog control

Equipment that needs jog control:

① Parameter setting: F0.02 = 1, F2.15 = 1 (FWD jog), F2.16 = 2 (REV jog). FWD jogging frequency is given by parameter F1.09, and REV jogging frequency is set by F1.10. Jog acceleration time is set by parameter F1.11, and Jog deceleration time is set by parameter F1.12.

② Wiring: FWD jog signal is connected to COM and S3, REV jog connected to COM and S4.

(4) Insufficient torque at low speed (turning hard)

Adjust parameters F0.14 from small to large gradually. Do not set an extreme value at the beginning because it may produce 0C over-current breakdown.

Adjust parameter to F0.15, which is the frequency of torque cut-off listing value.

(5) Applying on the carving machine which use the Weihong card

When applying on the carving machine which use the Weihong card

① Wiring: There are four wires on the Weihong Card, respectively the public wire, low-speed wire, medium-speed wire and high-speed wire. These four wires are

connected to the VFD COM, S3, S4, S5 respectively.

② Parameter setting: F0.02 = 1, F0.04 = 400 (set according to the motor nameplate), F0.05 = 400 (set according to the motor nameplate), F1.17 = 100, F1.18 = 150, F1.19 = 200, F1.20 = 250, F1.21 = 300, F1.22 = 350, F1.23 = 400, F2.17 = 15, F2.19 = 1.

F4.03 = 400 (motor rated frequency, set according to the motor nameplate).

③ After the parameter setting is completed, power-off, connect the terminals COM and S1 with wires. Then turn on the machine. (Note: the spindle may rotate after power on, so ensuring safety is important.

Service Delivers value, and quality creates brilliance

Dear every user:

Thank you for using our products. In order to ensure that you can receive the best after-sales service, please read the following terms, and finish related matters.

1.Scope of Product Guarantee

Any breakdown occurring under the normal use of product is within the scope of guarantee.

2.The Period of Guarantee

This product is guaranteed for twelve months, from the date of selling out of the factory. After the guarantee period, it is available to get long-term technical support services on product.

3.Beyond the Scope of Guarantee

Any violation of the requirements, due to human factors, natural disasters or water permeation, external damage, harsh environments etc., as well as unauthorized removal, modification and repair, will be considered as a waiver of guarantee service.

4.Buying Products from the Intermediary Businessmen

The users who buy products from the distributor and agent should contact the distributor or agent when breakdown happen on the product.

Please save this manual for future use if necessary.